

Neles™ Neldisc™ high performance butterfly valves

Series L6, LW & LG Model D

Neles Neldisc is a metal seated triple eccentric high performance butterfly valve that provides long lasting tight shut-off with excellent flow characteristics and high capacity. The L-Series are widely used in pulp & paper, chemical, petrochemical and refining industries.

With nearly equal percentage characteristics and superior tightness, Neldisc triple eccentric butterfly valves operate both in control and tight shutoff applications. As a result of the unique triple offset geometry of Neldisc, the contact between disc and seat is mechanically induced and does not rely on assistance from differential pressure. This design also provides extended operational life in control, high cycle, high temperature and abrasive applications.

Due to a number of special constructions, developed from the versatile Neldisc design, these valves offer a powerful tool for standardization and are truly high performance valves.

The Neldisc high-performance butterfly valve is available in double flange, wafer and lug body types with a range of materials and seat combinations suitable for service in a wide variety of applications including NACE MR0103 & MR0175.



Features

Offering

The following designs are available in sizes 3”–12” (DN 80–300);

	LW	LG	L6
Body type	Wafer	Lugged	Double flanged
Design	API 609 ASME B16.34 EN 593	API 609 ASME B16.34 EN 593	API 609 ASME B16.34 EN 593
Pressure class	API 609 Cat B Class 150 & 300	API 609 Cat B Class 150 & 300	API 609 Cat B Class 150 & 300
Face to face	API 609 category B, lug and wafer type EN 558 - part 1, table 5, basic series 16, 20 & 25	API 609 category B, lug and wafer type EN 558 - part 1, table 5, basic series 16, 20 & 25	API 609 category B valves Double-flanged (short pattern) EN 558 - part 1, table 5, basic series 13
Flange connection/ Drilling	ASME B16.5 EN 1092-1	ASME B16.5 EN 1092-1	ASME B16.5 EN 1092-1

Modularity

- Interchangeable modules ensure faster deliveries for a wide range of applications & minimizes parts required to stock on site
- Through shaft and drive shaft with trunnion options available
- Live-loaded packing as standard to minimize the product loss and emission.
- Same inside parts regardless of body design results in same flow characteristics and high Cv

Performance

- Cost effective control valve for moderate differential pressures.
- Contact between disc and seat is mechanically induced and does not rely on assistance from differential pressure.
- Heavy-duty stem and bearings arrangement extend service life and are insensitive to thermal cycles and impurities.
- Easier to withstand process fluctuations and harsh conditions for example flow vibration and temperature/ pressure changes.

- Easy seat maintenance: Interchangeable seat can be replaced without disassembling the disc and shaft.
- Seat replacement does not require any adjustment or special tools.
- Lugged and double flange style valves are suitable for bidirectional dead-end service at the full pressure temperature rating as standard.
- Lifting holes for valves weighting over 20 kg
- PTFE V-ring or graphite packing for a wide range of applications.

Field-proven single-piece flexible seat design

- Unique all-metal seat design assures superior tightness in difficult applications over long time periods
- Bi-directional long last tightness is maintained even in high cycle rate services.
- Low friction and excellent wear resistance.
- Longer service life with less maintenance
- Sealing element protected in the seat pocket for lowest wear & tear
- No secondary components required to maintain tightness
- No resilient parts exposed to the medium
- Solid metal seat design offers lowered operational torque which reduces actuator size

Offset shaft and eccentric disc

- No seat/disc contact in the open or intermediate position
- Eliminates wear points at top and bottom of seats for high cycle life
- Reduced torque requirements, allowing for smaller actuators

Approvals/Reliability/Safety

- ISO 15848-1 emission certification
- API 607 fire safe certification
- Anti-blow out design (Positive Shaft Retention). Valves are equipped with retainer plates on top of the gland to prevent movement of the top portion of the shaft past the gland if for any reason the shaft should break within the valve.

Excellent for both on-off and control applications

- Superior control characteristics
- Inherent flow characteristic is modified equal percentage.
- Wide rangeability
- Tight shut-off even in control applications
- Good controllability via smoothly rising installed characteristic curve at both very small openings and nearly full Cv positions. L-series provides very wide rangeability in fairly low pressure drop services.
- Good dynamic stability in both flow directions.

Neldisc triple eccentric sealing design

Neldisc high performance butterfly valves rely on triple eccentric sealing design. This unique design enables utilization of performance features from both positions seated and torque seated sealing principles resulting in high tightness level together with low wear. The disc of the valve is machined to close tolerances, to create an elliptical shape, similar to an oblique slice taken from a solid metal cone. When the valve is closed, the elliptical disc at the major axis displaces the seat ring outward, causing the seat ring to contact the disc at the minor axis. The seat ring is able to move freely in a plane in its recess, to accommodate the disc in an optimal manner. When the valve is opened, the contact is released, and the seat ring returns to its original circular shape. With slight changes to the machining of the disc the field proven Neldisc sealing principle is now optimized to reach even the toughest tightness standards.

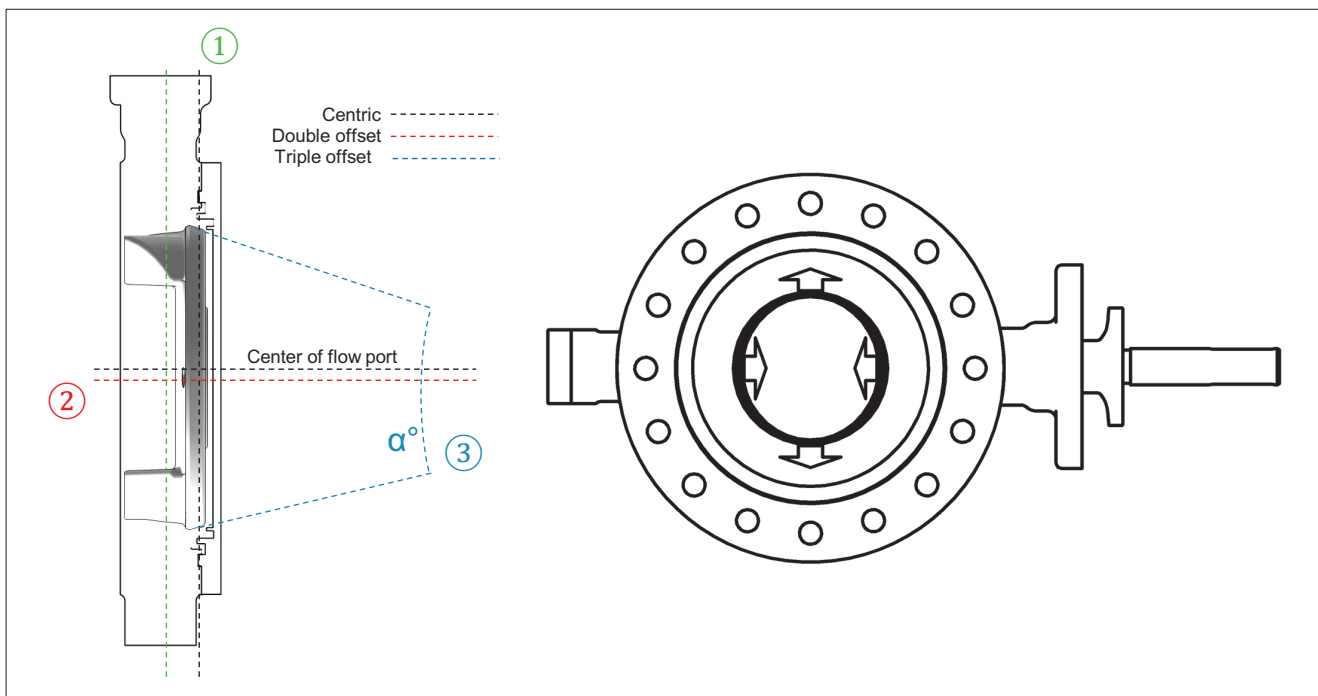

Triple eccentric sealing design. 1) First eccentricity, 2) Double offset, and 3) Triple offset

Valve construction

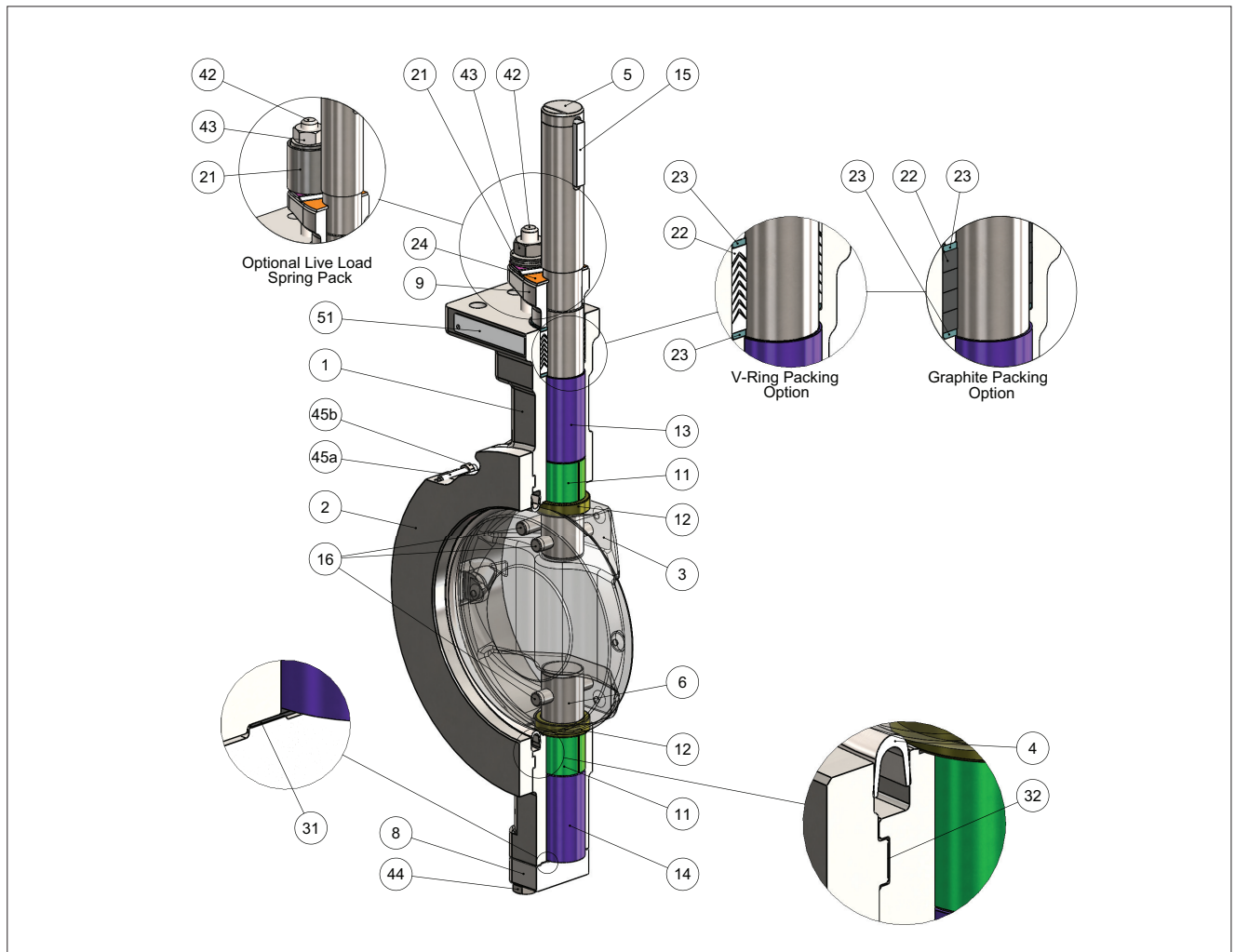

Part no.	Description	Material
1	BODY	ASTM A216 gr. WCB/1.0619 A351 gr. CF8M/1.4408
2	CLAMP RING	A351 gr. CF8M/1.4408
3	DISC	A351 gr. CF8M/1.4408
4	SEAT	UNS N08825+HCr
5	SHAFT	A564 gr. 630 H1150D ASTM A479 gr. 316
6	TRUNNION	A564 gr. 630 H1150D ASTM A479 gr. 316
8	BLIND FLANGE	A351 gr. CF8M/1.4408
9	GLAND	A351 gr. CF8M/1.4408
11	BEARING	316L+RPTFE 625+PVDC COBALT BASED ALLOY
12	THRUST BEARING	ASTM A269 gr.316+HCr
13	BEARING SPACER	AISI 316 PTFE
14	BEARING SPACER	AISI 316 PTFE
15	KEY	EN 10088-1.4460 A564 gr. 630 H1150D

Part no.	Description	Material
16	PIN	A564 gr. 630 H1150D ASTM A479 gr. 316
21	DISC SPRING SET	AISI 303//50CrV4+ENP AISI 304
22	PACKING RING SET	GRAPHITE PTFE
23	ANTI EXTRUSION RING	AISI 316
24	RETAINER	AISI 316
31	GASKET	GRAPHITE
32	BODY GASKET	GRAPHITE
42	STUD	ASTM A193 gr. B8M cl. 2
43	HEXAGON NUT	ASTM A194 gr. 8M
44	HEXAGON SCREW	ASTM A193 gr. B8M cl. 2
45	SOCKET HEAD SCREW	ASTM A320 gr. L7M ASTM A193 gr. B8M cl. 2
45a	STUD	ASTM A193 gr. B8M cl. 2
45B	HEXAGON NUT	ASTM A194 gr. 8M
51	IDENTIFICATION PLATE	AISI 316

Technical specifications

Product type

- L6: Double flange body design
- LW: Wafer type body design
- LG: Lug type body design

Size range

- NPS 3"-12"
- DN 80-300

Pressure classes

- ASME 150 & ASME 300
- PN 10-40

Temperature range

- -200 ... +600 °C (-328 ...+1112 °F)

Design standard

In accordance with ASME B16.34, API 609 cat B, EN 593

Standard materials

Body:	EN 10213-1.0619 / ASTM A 216 gr. WCB EN 10213-1.4408 / ASTM A 351 gr. CF8M
Disc:	EN 10088-1.4401 / ASTM A 182 gr. F316 EN 10213-1.4408 / ASTM A 351 gr. CF8M
Clamp ring:	EN 10213-1.4408 / ASTM A 351 gr. CF8M
Shafts and pins:	AISI 316 / ASTM A 546 gr. 630 (17-4PH)
Seat ring, code A:	Hard chrome plated Incoloy 825
Bearings:	AISI 316 + PTFE or INC625 + carbon-based coating or cobalt based alloy

Material and test certifications

EN 10204-3.1B material certificates for body, clamp ring, gland and blind flange. Disc and shaft certification on request. Tightness test certificate.

Approvals

- API 607 fire safe
- ISO 15848-1 fugitive emission
- TSG
- TR-CU
- SIL

Tightness (Bi-directional)

- Standard tightness
 - ISO 5208, rate D, air
 - ANSI/FCI 70-2 Class V, air
 - 10 x ISO 5208 rate D with RH hand lever
- Optional tightness:
 - API 598 (metal seated),
 - ANSI/FCI 70-2 Class VI
 - ISO 5208 rate A

Optional leakage tests can be conducted per request.

Options

- Neles™ Q-disc™ flow balancing trim, see bulletin 8QD20EN
- Oxygen construction for gaseous oxygen service
- High temperature design
- Extended service design
- Bearing protection design
- Graphite free design
- Cryogenic construction with extended bonnet and drive shaft
- L series valves are available to comply with NACE MR0103 or NACE MR0175

Pressure/temperature ratings for valve body, WCB

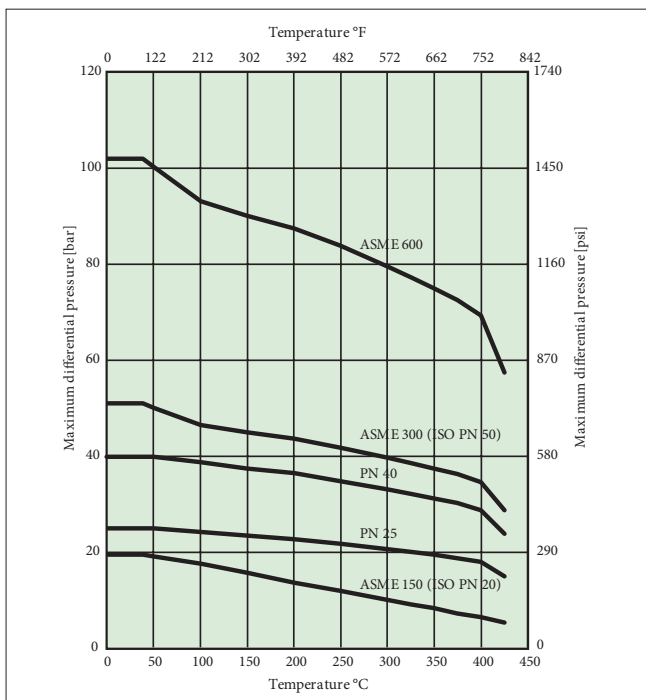

Pressure/temperature ratings for valve body, CF8M

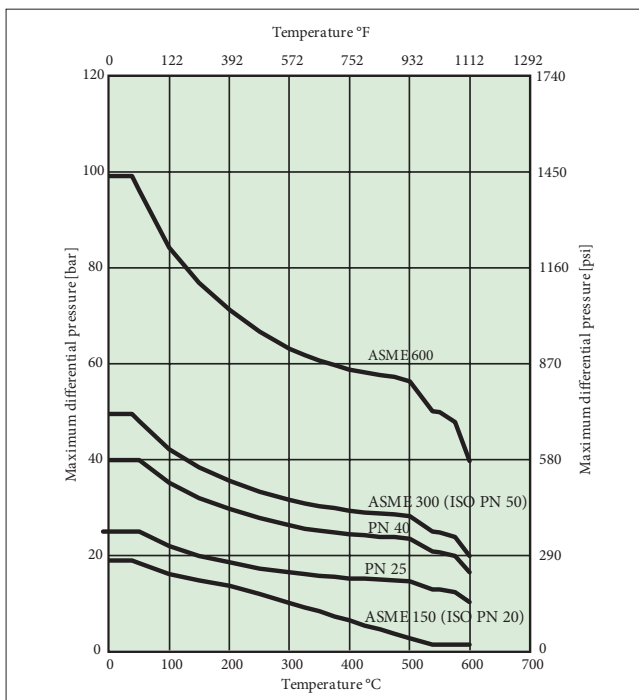

Flow data

The tables below provide flow coefficients for L-Series butterfly valves covered in this bulletin. The Cv values represent the number of gallons per minute of +60°F water that flows through a fully open valve at a pressure drop of 1 psi. The metric equivalent Kv is the flow of water at 16°C through the valve in cubic meters per hour at a pressure drop of 1kg/cm². To convert Cv to Kv multiply by 0.8569.

Inch	DN	Design style	Cv	
			ASME 150	ASME 300
3	80	Through shaft	220	220
4	100	Through shaft	357	357
6	150	Through shaft	1240	1020
8	200	Through shaft	1990	1670
10	250	Through shaft	3470	3150
12	300	Through shaft	5320	4050

Inch	DN	Design style	Cv	
			ASME 150	ASME 300
3	80	Drive shaft + trunnion	247	247
4	100	Drive shaft + trunnion	482	482
6	150	Drive shaft + trunnion	1630	1260
8	200	Drive shaft + trunnion	2400	1810
10	250	Drive shaft + trunnion	4460	3600
12	300	Drive shaft + trunnion	6820	4670

Valve torque data

Inch	DN	Pressure class	Closing torque [Nm]
3"	80	ASME 150	60
4"	100	ASME 150	100
6"	150	ASME 150	150
8"	200	ASME 150	350
10"	250	ASME 150	500
12"	300	ASME 150	800

Inch	DN	Pressure class	Closing torque [Nm]
3"	80	ASME 300	60
4"	100	ASME 300	100
6"	150	ASME 300	230
8"	200	ASME 300	400
10"	250	ASME 300	700
12"	300	ASME 300	1100

Dimensions

L6, Double flanged design

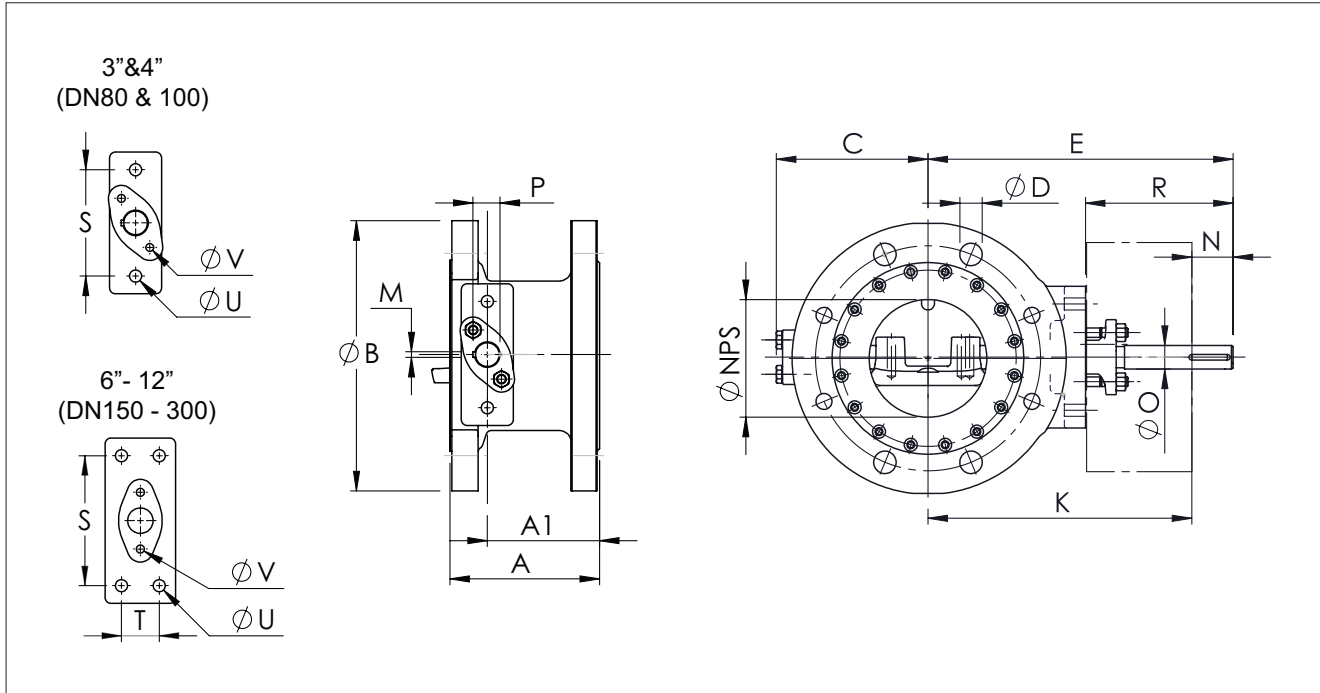

L64 (ASME 150, PN10-16)

DN	NPS	Dimensions (mm)																Weight (Kg)
		A (API/ Series 13)	A1	øB	C	D	E	K	M	N	O	P	R	S	T	U	V	
80	3	114	86	190	109	19	226	201	4.8	25	15	17.0	105	70	-	M10	M8	10
100	4	127	95	230	129	19	258	223	4.8	35	20	22.2	125	90	-	M12	M8	18
150	6	140	107	280	159	22	277	242	4.8	35	20	22.2	125	110	32	M12	M8	26
200	8	152	115	345	187	22	323	277	6.4	46	25	27.8	136	110	32	M12	M10	43
250	10	165	125	405	226	25	393	342	6.4	51	30	32.9	161	130	32	M12	M12	61
300	12	178	134	485	262	25	428	370	9.5	58	35	39.1	168	130	32	M12	M12	94

L64 (ASME 300, PN25-40)

DN	NPS	Dimensions (mm)																Weight (Kg)
		A (API/ Series 13)	A1	øB	C	D	E	K	M	N	O	P	R	S	T	U	V	
80	3	114	86	210	109	22	226	201	4.8	25	15	17.0	105	70	-	M10	M8	15
100	4	127	95	255	129	22	258	223	4.8	35	20	22.2	125	90	-	M12	M8	25
150	6	140	104	320	178	22	321	275	6.4	46	25	27.8	136	110	32	M12	M10	47
200	8	152	108	380	215	25	381	323	9.5	58	35	39.1	168	130	32	M12	M12	71
250	10	165	117	445	254	29	442	374	9.5	68	40	44.2	188	160	40	M16	M12	108
300	12	178	124	520	301	32	535	445	12.7	90	50	55.5	230	160	55	M20	M16	169

LW, Wafer design

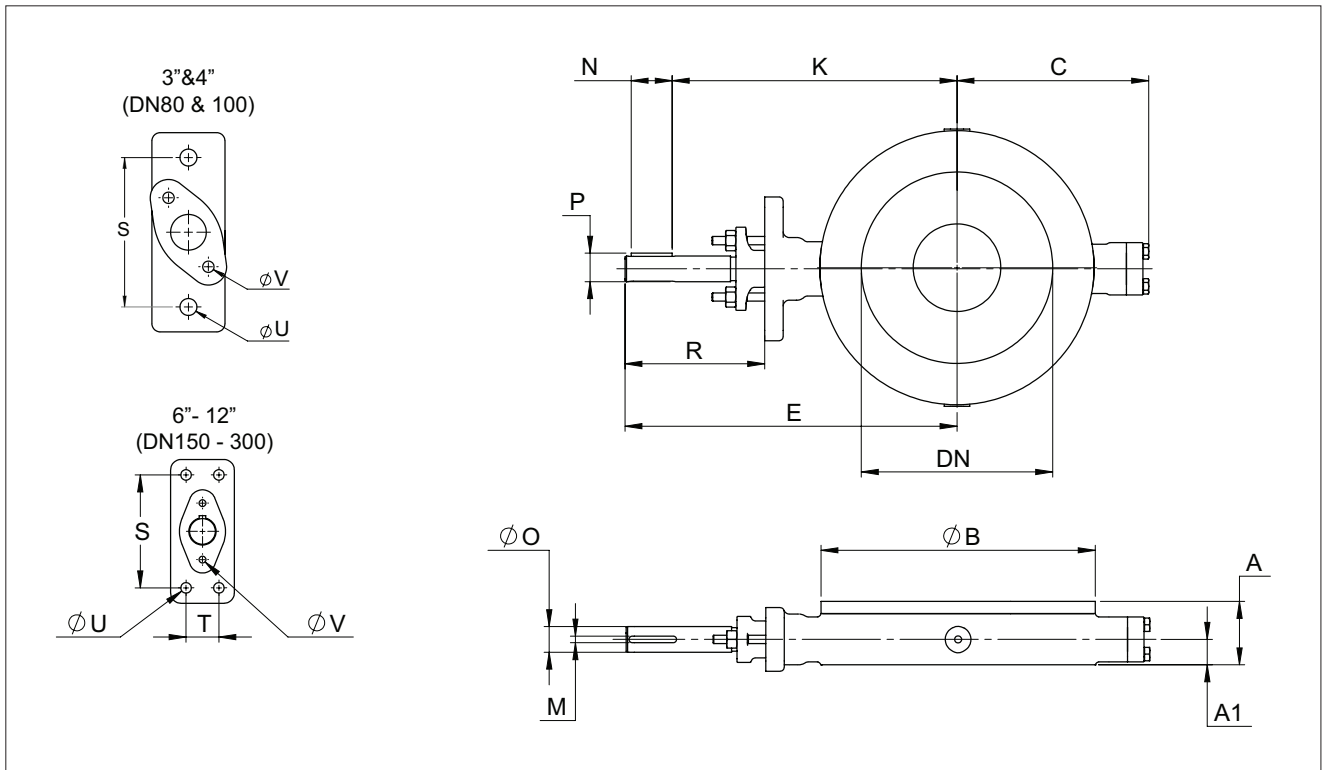

LW6 & LW7 (ASME 150, PN10-16)

DN	NPS	Dimensions (mm)																	Weight (kg)
		LW6 A (K1/ API/ Series 20)	LW7 A (K2/ Series 25)	A1	B	C	E	K	M	N	O	P	R	S	T	U	V		
80	3	48	49	20	131	109	226	201	4.8	25	15	17.0	105	70	-	M10	M8	5	
100	4	54	56	22	156	129	258	223	4.8	35	20	22.2	125	90	-	M12	M8	7	
150	6	57	70	24	217	159	277	242	4.8	35	20	22.2	125	110	32	M12	M8	14	
200	8	64	71	25	267	187	323	277	6.4	46	25	27.8	136	110	32	M12	M10	21	
250	10	71	76	30	328	226	393	342	6.4	51	30	32.9	161	130	32	M12	M12	32	
300	12	81	83	37	375	262	428	370	9.5	58	35	39.1	168	130	32	M12	M12	44	

LW5 & LW8 (ASME 300, PN25-40)

DN	NPS	Dimensions (mm)																	Weight (kg)
		LW5 A (K1/ API)	LW8 A (K3/ Series 16)	A1	B	C	E	K	M	N	O	P	R	S	T	U	V		
80	3	48	64	20	131	109	226	201	4.8	25	15	17.0	105	70	-	M10	M8	6	
100	4	54	64	22	156	129	258	223	4.8	35	20	22.2	125	90	-	M12	M8	8	
150	6	59	76	25	217	178	321	275	6.4	46	25	27.8	136	110	32	M12	M10	16	
200	8	73	89	32	280	215	381	323	9.5	58	35	39.1	168	130	32	M12	M12	35	
250	10	83	114	38	340	254	442	374	9.5	68	40	44.2	188	160	40	M16	M12	60	
300	12	92	114	41	400	301	535	445	12.7	90	50	55.5	230	160	55	M20	M16	91	

LG, Lug design

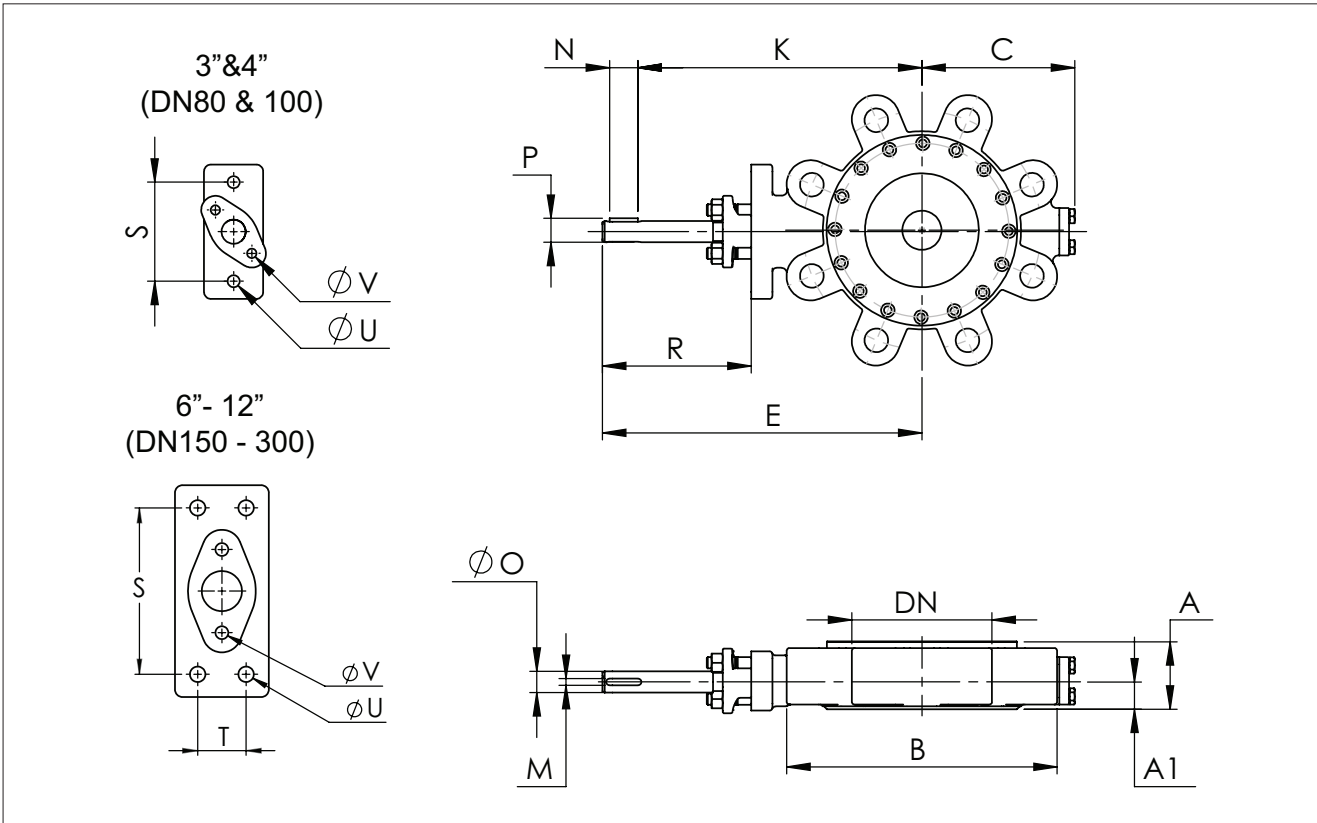

LG6 & LG7 (ASME 150, PN10-16)

DN	NPS	Dimensions (mm)																Weight (kg)
		LG6 A (K1/ API/ Series 20)	LG7 A (K2/ Series 25)	A1	B	C	E	K	M	N	O	P	R	S	T	U	V	
80	3	48	49	20	135	109	226	201	4.8	25	15	17.0	105	70	-	M10	M8	8
100	4	54	56	22	222	129	258	223	4.8	35	20	22.2	125	90	-	M12	M8	13
150	6	57	70	24	257	159	277	242	4.8	35	20	22.2	125	110	32	M12	M8	18
200	8	64	71	25	319	187	323	277	6.4	46	25	27.8	136	110	32	M12	M10	30
250	10	71	76	30	391	226	393	342	6.4	51	30	32.9	161	130	32	M12	M12	43
300	12	81	83	37	458	262	428	370	9.5	58	35	39.1	168	130	32	M12	M12	59

LG5 & LG8 (ASME 300, PN25-40)

DN	NPS	Dimensions (mm)																Weight (kg)
		LG5 A (K1/ API)	LG8 A (K3/ Series 16)	A1	B	C	E	K	M	N	O	P	R	S	T	U	V	
80	3	48	64	20	191	109	226	201	4.8	25	15	17.0	105	70	-	M10	M8	10
100	4	54	64	22	222	129	258	223	4.8	35	20	22.2	125	90	-	M12	M8	14
150	6	59	76	25	306	178	321	275	6.4	46	25	27.8	136	110	32	M12	M10	28
200	8	73	89	31	365	215	381	323	9.5	58	35	39.1	168	130	32	M12	M12	46
250	10	83	114	37	431	254	442	374	9.5	68	40	44.2	188	160	40	M16	M12	84
300	12	92	114	40	493	301	535	445	12.7	90	50	55.5	230	160	55	M20	M16	113

Dimensions for valves with square shaft connection

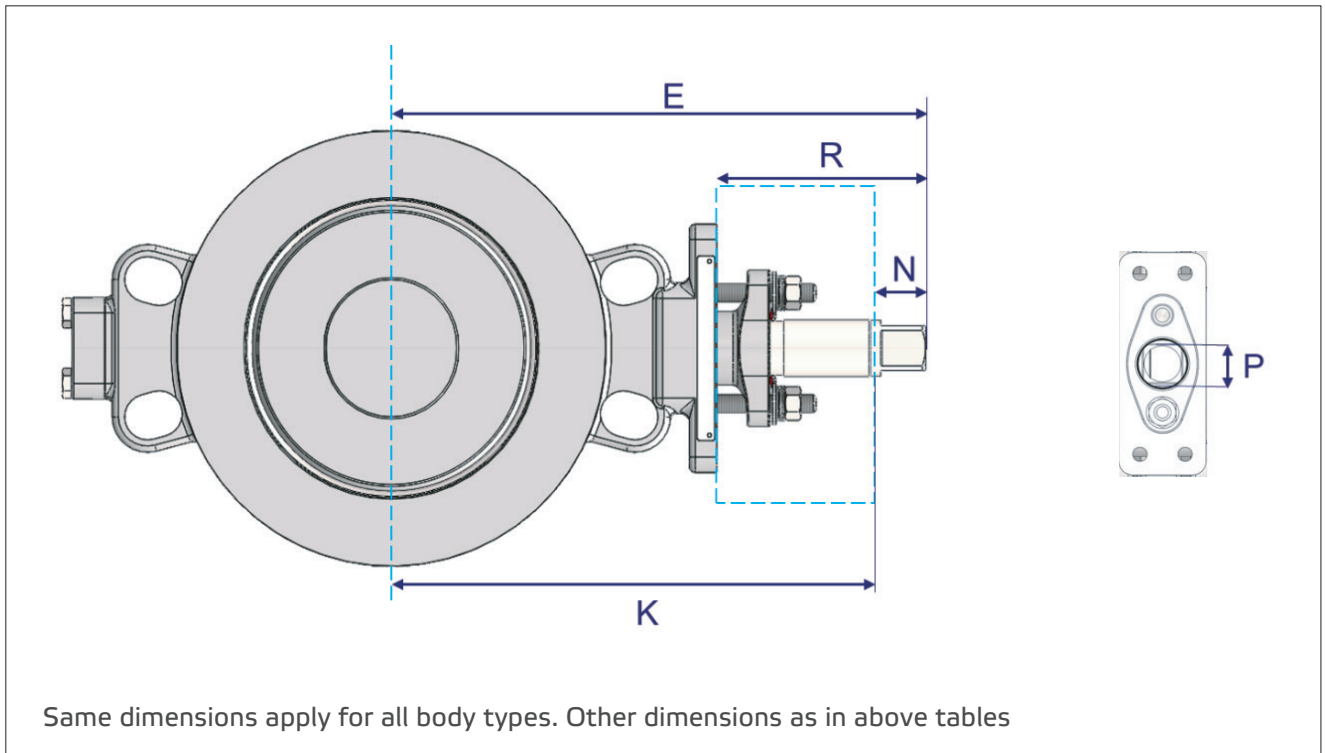

ASME 150, PN10-16

Size		E	K	N	P	R
DN	Inch					
80	3	213	201	12	11	92
100	4	239	223	16	14	106
150	6	258	242	16	14	106
200	8	298	277	21	19	111
250	10	366	342	24	22	134
300	12	399	370	29	27	139

ASME 300, PN25-40

Size		E	K	N	P	R
DN	Inch					
80	3	213	201	12	11	92
100	4	239	223	16	14	106
150	6	296	275	21	19	111
200	8	352	323	29	27	139
250	10	406	374	32	30	152
300	12	483	445	38	36	178

Type code

1.	2.	3.	4.	5.	6.	7.	8.	9.	10.	11.	12.	13	14.
-	LW	6	K	B	A	200	A	A	A	A	T	D	-

1. sign	FLOW BALANCING CONSTRUCTION
-	Standard construction
Q-	Flow balancing trim, Q-disc

2 sign	PRODUCT SERIES / DESIGN
LW	Wafer type, metal seated triple eccentric butterfly valve
LG	Lug type, metal seated triple eccentric butterfly valve
L6	Double flange type, metal seated triple eccentric butterfly valve

3. sign	FACE TO FACE
LW & LG	
6	EN 558-part 1, table 5 / basic series 20 (DIN 3202-K1) (with PN10-16) API 609 category B class 150 (with ASME 150)
7	EN 558-part 1, table 5 / basic series 25 (DIN 3202-K2) (with PN 10-16 and ASME 150)
8	EN 558-part 1, table 5 / basic series 16 (DIN 3202-K3) (with PN25-40)
5	API 609 category B class 300 (with PN 25-40 and ASME 300)
L6	
4	API 609 category B, Double-flanged (short pattern) (with all pressure classes)

4. sign	PRESSURE RATING & DRILLING
C	ASME 150
D	ASME 300
J	PN 10
K	PN 16
L	PN 25
M	PN 40

5. sign	VALVE-ACTUATOR CONNECTION AND SHAFT CONSTRUCTION
B	Drive shaft + trunnion with two keyways / bracket according to manufacturer standard
A	Through shaft with two keyways / bracket according to manufacturer standard
D	Drive shaft + trunnion with square drive / bracket according to manufacturer standard

6. sign	CONSTRUCTION
A	STANDARD (max +260 °C) <ul style="list-style-type: none"> Bearings 316 + PTFE-based coating Body and blind flange gaskets graphite A construction fulfills NACE MR0175 for LW Anti-static device with PTFE packing: ATEX II 3 G c with graphite packing: ATEX II 2 G c
N/1N	EXTENDED SERVICE (max. +425 °C) <ul style="list-style-type: none"> Bearings Inconel 625 + PVDC coating Body and blind flange gaskets graphite N construction fulfills NACE MR0175 for LW with A seat 1N construction fulfills NACE MR0175 for L6 and LG with A seat NACE compliant clamp ring bolting <ul style="list-style-type: none"> Anti-static device with PTFE packing: ATEX II 3 G c with graphite packing: ATEX II 2 G c
H/1H	HIGH TEMPERATURE SERVICE (max. +600 °C) <ul style="list-style-type: none"> Cobalt based alloy bearings Shaft cobalt-based material coated Body and blind flange gaskets graphite H construction fulfills NACE MR0175 for LW with A seat 1H construction fulfills NACE MR0175 for L6 and LG with A seat NACE compliant clamp ring bolting <ul style="list-style-type: none"> Anti-static device: ATEX II 2 G c
B	BEARING PROTECTION (max. +260 °C) <ul style="list-style-type: none"> PTFE bearing protection Back space of seat filled to prevent accumulation of process fluid Otherwise as A construction
1B	BEARING PROTECTION FOR EXTENDED SERVICE (max. +425 °C) <ul style="list-style-type: none"> Graphite bearing protection Otherwise as N construction
Z	OXYGEN SERVICE (max. +200 °C) <ul style="list-style-type: none"> BAM/WHA approved soft parts T = -50 °C ... +200 °C Oxygen cleaning according to manufacturer internal procedure FC-M-1360-En Note! No carbon steel body material allowed. Note! Only "Z" construction available for oxygen flow media. Not to be used with other flow medias.
1A	GRAPHITE FREE (PTFE SOFT PARTS) (max. +260 °C) <ul style="list-style-type: none"> Body and blind flange gaskets PTFE Otherwise as A construction
C	CRYOGENIC (Standard Cryo extension) <ul style="list-style-type: none"> Extended bonnet and drive shaft (Cryo extension for T = -200 °C to +260°C) Additional gaskets and bearings Otherwise as "A" construction
7. sign	SIZE (inches / mm)
ASME	03, 04, 06, 08, 10, 12
PN	080, 100, 150, 200, 250, 300

8. sign	BODY	9. sign	DISC	10. sign	SHAFT & PINS
Note: Material coding specifies only the type of material not grade (cast, wrought, bar, forged...) which can change based on size or type. Below material combinations are not fixed by each row.					
A	CF8M / 1.4408	A	CF8M/ F316	A	AISI 316 (strain hardened) Not suitable with ASME 300 (sign 4 D)
P	WCB / 1.0619		-	C	Gr. 630 (17-4PH)
A1	ASTM A351 gr. CF8 / AISI 304	A1	ASTM A351 gr. CF8 / AISI 304	N	XM-19 (Nitronic 50)
A2	ASTM A351 gr. CF3M / AISI 316L	A2	ASTM A351 gr. CF3M / AISI 316L	H	Nimonic 80A
A3	ASTM A351 gr. CF3 / AISI 304L	A3	ASTM A351 gr. CF3 / AISI 304L	-	-
A4	ASTM A351 gr. CF8C / AISI 347	A4	ASTM A351 gr. CF8C / AISI 347	-	-
F	ASTM A352 gr. LCC	B	CF8M / F316+ cobalt based alloy on disc edge	-	-
F1	ASTM A352 gr. LCB	-	-	-	-
C	ASTM A351 gr. CG8M / AISI 317	C	ASTM A351 gr. CG8M / AISI 317	-	-
C1	ASTM A351 gr. CG3M	C1	ASTM A351 gr. CG3M	-	-
P1	ASTM A216 gr. WCC	-	-	-	-
U2	ASTM A995 gr. 4A / EN 10213 - 1.4517	U2	ASTM A995 gr. 4A / EN 10213 - 1.4517		
U3	ASTM A995 gr. 5A / EN10213 - 1.4469	U3	ASTM A995 gr. 5A / EN 10213 - 1.4469	U3	UNS 32750

11. sign	STANDARD SEAT
A	Incoloy 825 (=UNS N08825), hard chrome plated T = -200 °C ... + 500 °C, (Nace MR 0103/MR0175)
H	Nimonic 80A (UNS N07080), hard chrome plated T = -200 °C ... + 650 °C, (Not Nace)
K	W. No. 2.4681, UNS R31233 (ULTIMET) T = -200 °C ... + 600 °C, (Nace MR 0103)

12. sign	SHAFT SEAL OPTIONS
T	Standard live loaded PTFE V-ring packing (ISO15848-1 certified)
G	Standard live loaded graphite packing (Fire safe and ISO15848-1 certified)
T1	High performance live loaded PTFE V-ring packing (ISO15848-1 certified)
G1	High performance live loaded graphite packing (Fire safe and ISO15848-1 certified)

13. sign	
D	Mod D, modular butterfly valve platform

14. sign	STANDARD FLANGE FINISHING Special flange finish shall always be marked in type code.
-	Ra 3.2 - 6.3, standard, without sign cover: EN 1092-1 Type B1 (Ra 3.2 - 12.5) ASME B16.5, Ra 3.2 - 6.3 (125 - 250 µin) DIN 2526 Form E (Ra 4)

Valmet Flow Control Oy

Vanha Porvoontie 229, 01380 Vantaa, Finland.

Tel. +358 10 417 5000.

www.valmet.com/flowcontrol

Subject to change without prior notice.

Neles, Neles Easyflow, Jamesbury, Stonel, Valvcon and Flowrox, and certain other trademarks, are either registered trademarks or trademarks of Valmet Oyj or its subsidiaries in the United States and/or in other countries.

For more information www.neles.com/trademarks

